

STRUCTURAL STEEL BILL OF MATERIAL

MARK	QTY	DESCRIPTION	LENGTH		WEIGHT		REMARKS
			FEET	INCHES	EACH	EXT	
A13	2	ASSEMBLY	-	-	741.2	1482.4	
T15	1	HSS 8 X 8 X 1/4	21	4	550.8	550.8	
P5111	2	PL 3/4 X 14	1	2	41.7	83.4	
P508	3	PL 1/4 X 16	2	7	35.2	105.6	
E2	2	3/4 X 9 GA X 8"	0	8	0.7	1.4	
A14	2	ASSEMBLY	-	-	606.3	1212.6	
T16	2	HSS 6 X 2 X 1/4	19	11	3/4	244.1	488.2
T17	5	HSS 6 X 2 X 1/4	1	5	19.3	96.5	
L8	6	L 3 X 3 X 3/8	0	6	3.6	21.6	
A51	12	ASSEMBLY	-	-	4.0	48.0	
P556	1	PL 1/4 X 7	0	8	4.0	4.0	

TOTAL WEIGHT THIS SHEET (NOT INCLUDING FINISH): 2723.0 POUNDS

ERECTOR BOLTS			
20	EACH	3/4"	DIA 2 3/4"
20	EACH	5/8"	DIA 3 1/2"
15	EACH	1/2"	DIA 1"
	EACH		DIA

LONG A325 BOLTS WITH HEAVY HEX NUT AND HARDENED WASHER.  
LONG A325 BOLTS WITH HEAVY HEX NUT AND HARDENED WASHER.  
LONG A307 BOLTS WITH HEAVY HEX NUT AND HARDENED WASHER.

ALL BOLTS AND HARDWARE SHALL BE GALVANIZED

MARK	MATERIAL	FINISH
	HSS SHAPES	AS1W A500, GRADE B
	PIPE	AS1W A53, GRADE B
	ALL OTHER STEEL	AS1W A36, UNLESS SPECIFIED OTHERWISE
		HOT DIP GALVANIZED

- NOTES
- WELDING ELECTRODES SHALL BE E70XX.
  - VERIFY DIMENSION WITH ENGINEER BEFORE FABRICATION.
  - ALL FLAT PLATES SHALL BE PROCESSED USING COMPUTERIZED MACHINES FOR ACCURACY IN CUTTING BOLT HOLE PATTERNS & SLOTS.

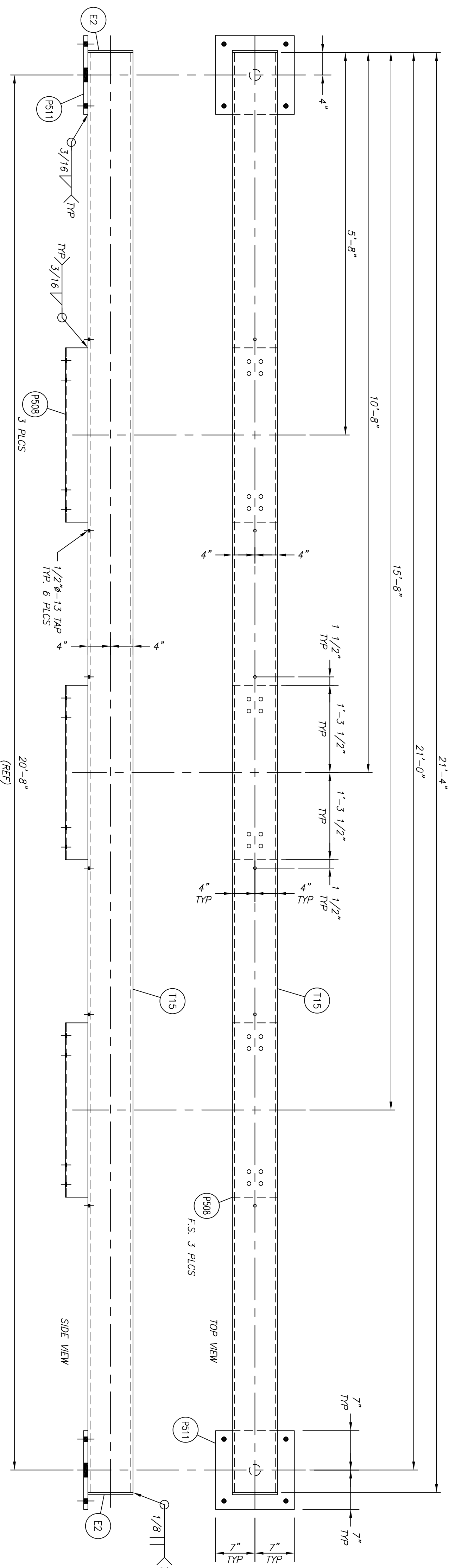

A13 ASSEMBLY  
15 KV REGULATOR BYPASS  
SCALE: 1"=1'-0"

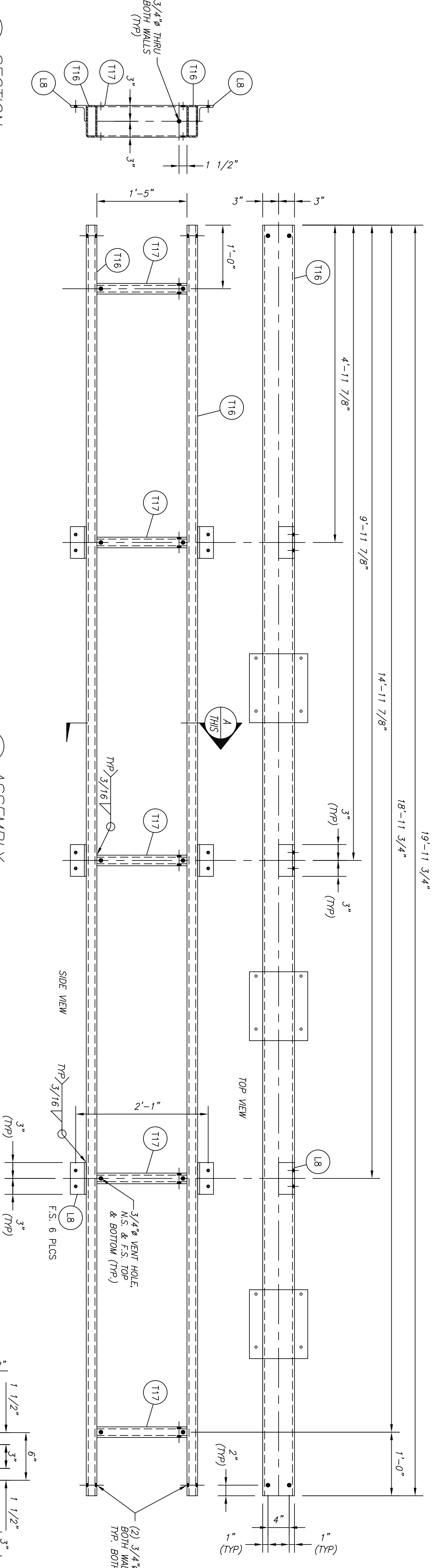

A14 ASSEMBLY  
15 KV REGULATOR BYPASS  
SCALE: 1"=1'-0"

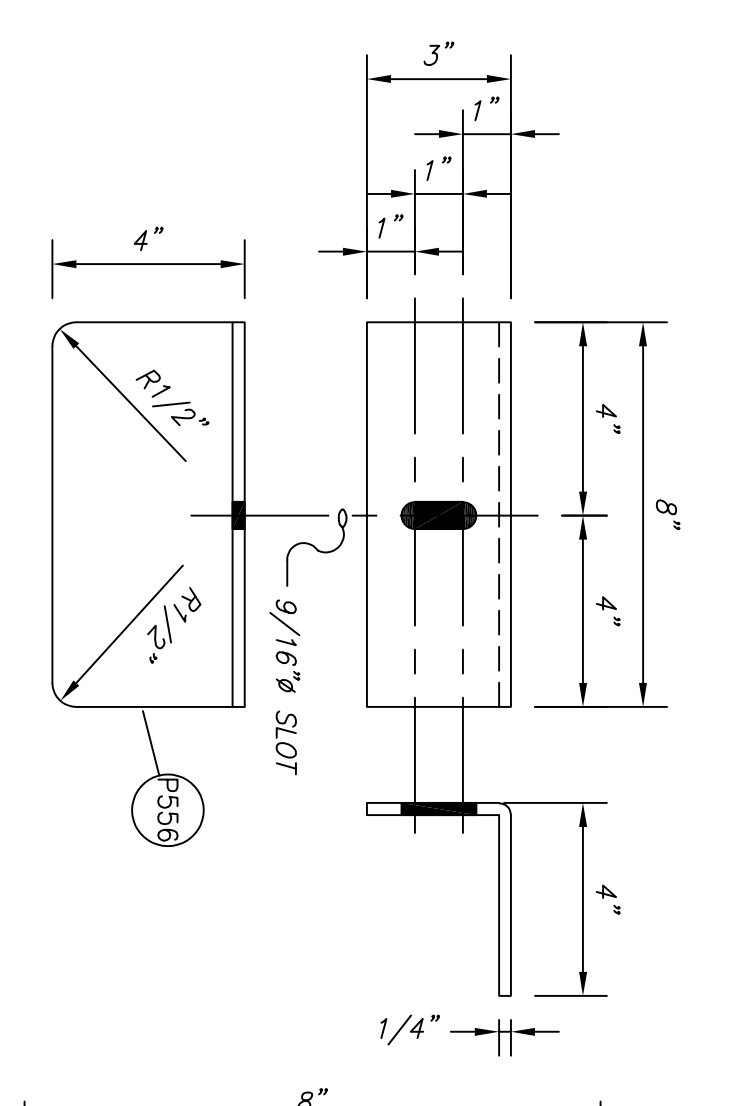

A51 ASSEMBLY  
BIRD GUARD  
PL 1/4 X 7 X 0'-8"  
WEIGHT: 4.0 #  
SCALE: 1/4"=1"

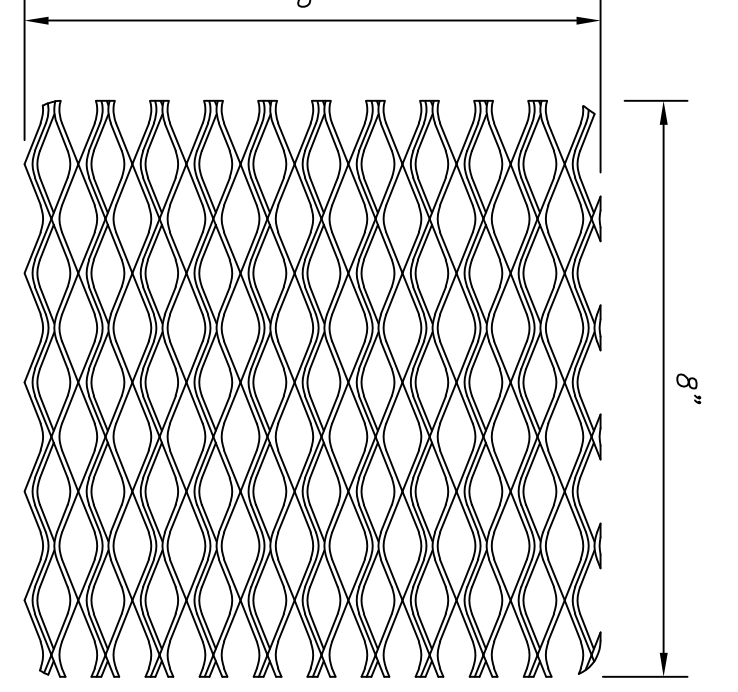

E2 DETAIL  
3/4" X 9 GA X 8" EXP. METAL  
WEIGHT: 0.7 #  
SCALE: 3/8"=1"

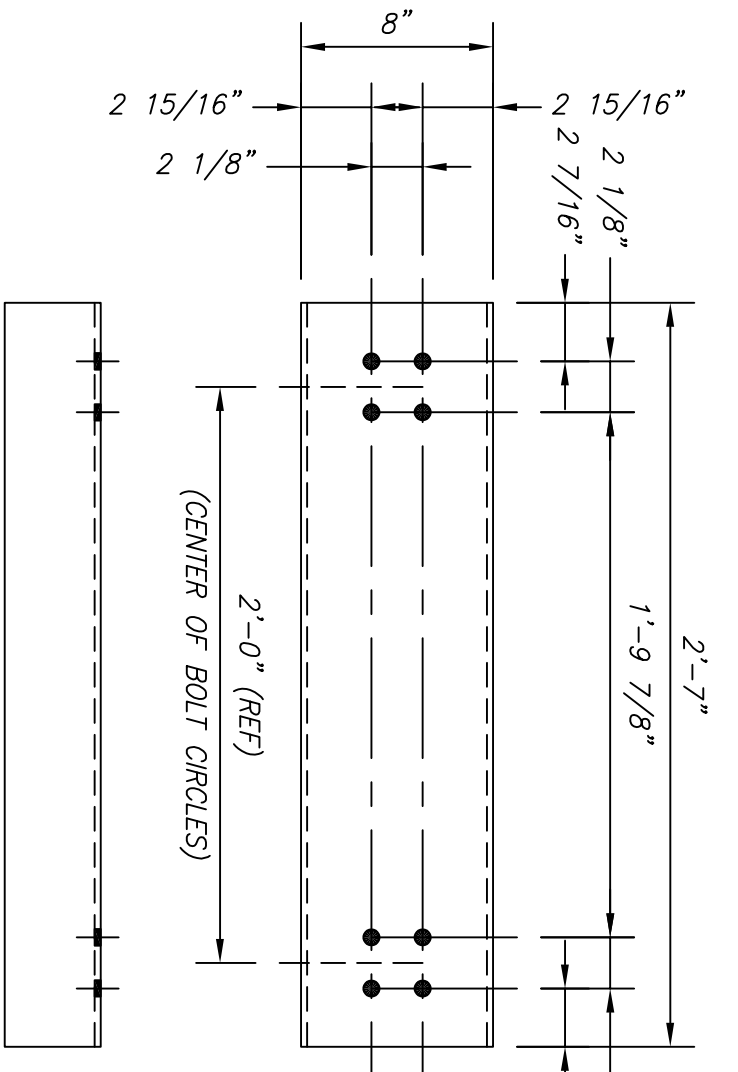

P508 DETAIL  
PL 1/4 X 16 X 2'-7" (BENT)  
WEIGHT: 35.2 #  
SCALE: 1/8"=1"

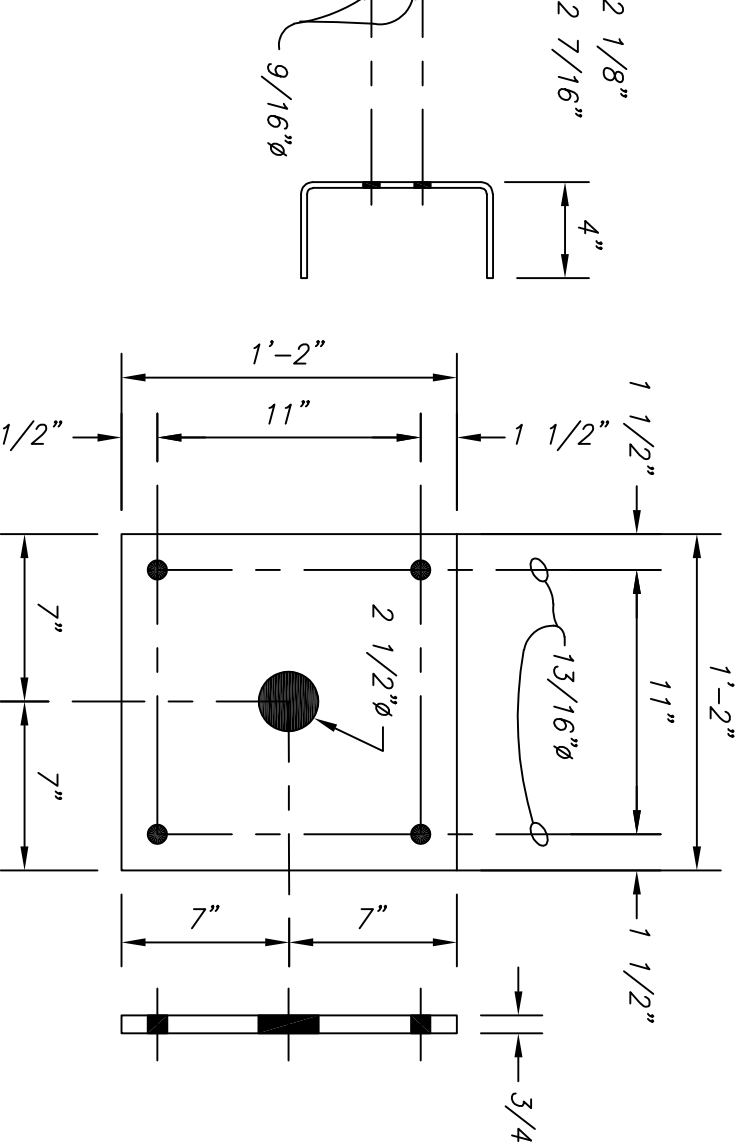

P511 DETAIL  
PL 3/4 X 14 X 1'-2"  
WEIGHT: 41.7 #  
SCALE: 1/8"=1"

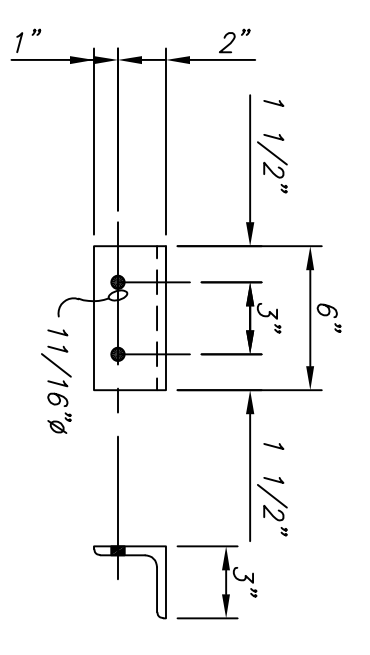

L8 DETAIL  
L3 X 3 X 3/8 X 0'-6"  
WEIGHT: 3.5 #  
SCALE: 1/8"=1"

TONA-S10-02

REV.	DATE	FILE NAME:
A	10/16/19	15KV REGULATOR BYPASS.DWG
0	10/31/19	15KV REGULATOR BYPASS.DWG

Project: 115/13.8KV SUBSTATION  
Drawing: 15KV REGULATOR BYPASS

DESIGNED	ENGINEER	DRAWN	SHEET
KMS	AMN	DRL	2 OF 3
SCALE	W.D. NO.	DATE	DWG #
AS SHOWN	XXXXXXXX	10/16/19	TONA-S10-02

OKANOGAN COUNTY PUD NO. 1